

BILL OF MATERIALS

PART	QTY	NAME	DESCRIPTION
1	1	HOLDER	12L14 STEEL, Ø1-3/8" x 2"
2	1	CAP	12L14 STEEL, Ø1-3/8" x 7/8"
2 alt.	1	CAP (alternate)	ER20 Collet Chuck Hex Cap ETM Part No. 4513025 or equal by others
3	2	RETAINING SCREW	6-32 X 3/8 HSSS (modified)

ER20 COLLET HOLDER

for the
Atlas/Craftsman 6 Lathe

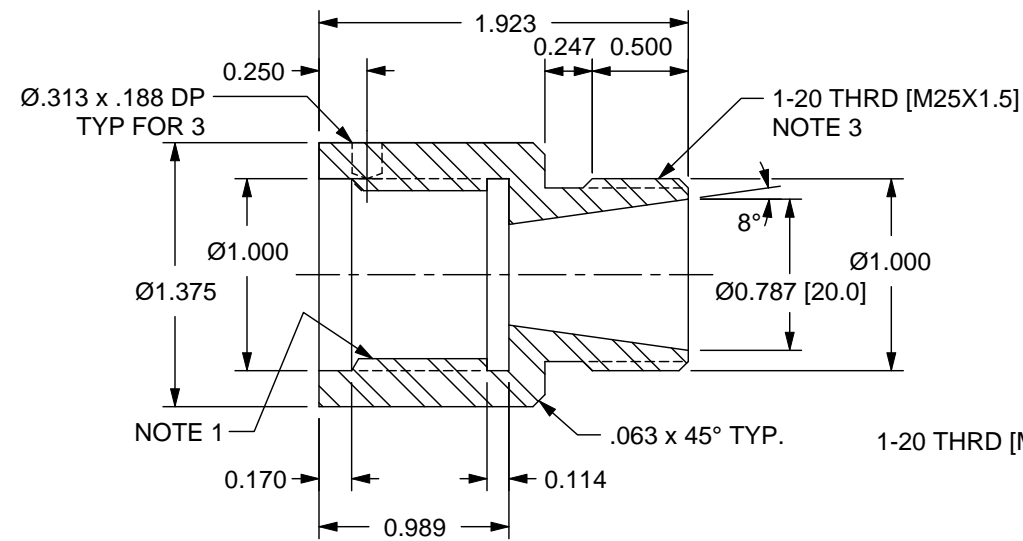
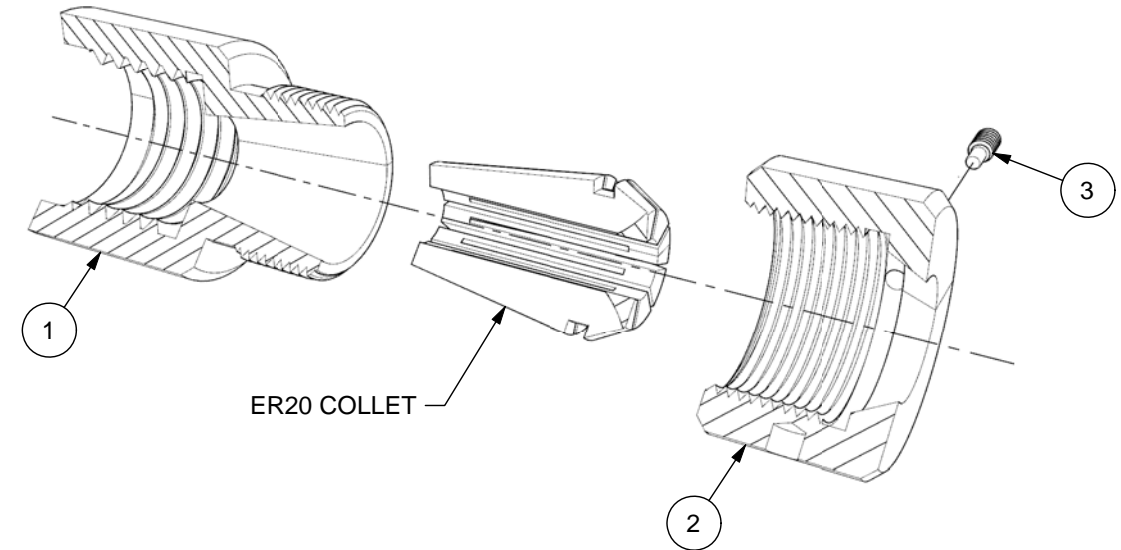
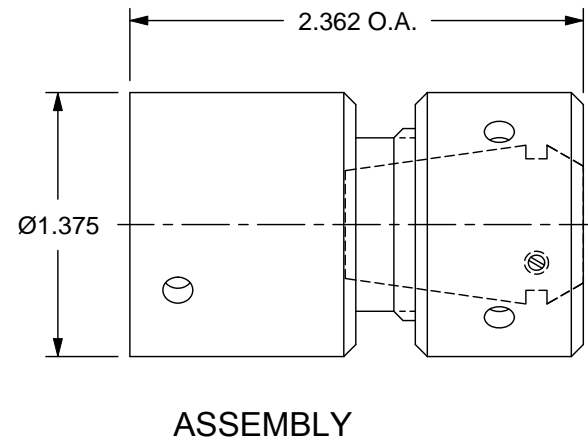

1 HOLDER
mat'l - steel
1 required

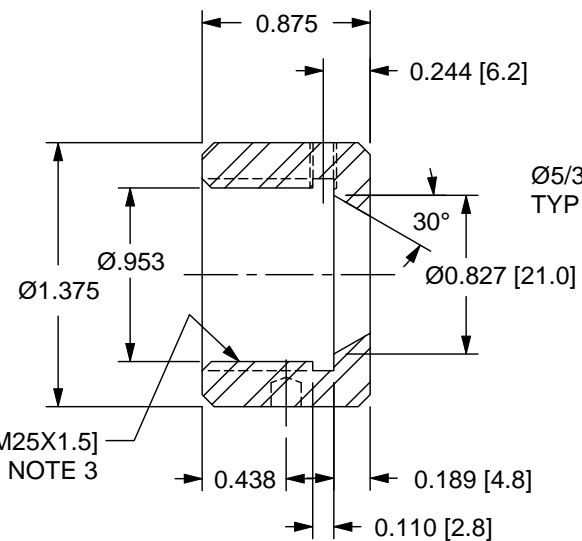

2 CAP
mat'l - steel
1 required

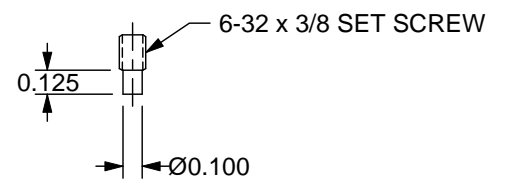
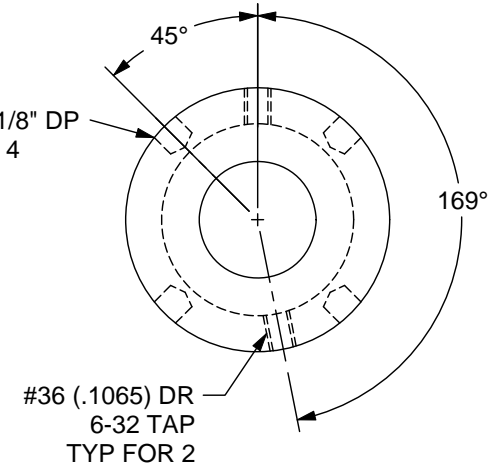

3 RETAINER SCREW
mat'l - set screw
2 required

- NOTES
- VERIFY LATHE SPINDLE NOSE: (OLDER MODEL) 1-8 THREAD (NEWER MODEL) 1-10 THREAD
 - METRIC DIMENSIONS = [XX.X]
 - METRIC THREADS GIVEN FOR USE WITH ALTERNATE COMMERCIALY MADE ER HEX CAPS

© 2013 Robert M. Rudowski
Purchaser may photocopy these drawings as an aid to personal or commercial use but does not have the right to distribute copies of these drawings to others.

www.DownriverTools.com
Wyandotte, MI

ER20 COLLET HOLDER
for ATLAS/CRAFTSMAN 6" LATHE

REV	DESCRIPTION	DATE	ISSUED: 5-3-13	PROJ NO: 76010	DWG NO: 01
-----	-------------	------	----------------	----------------	------------